

Product Catalogue



CONTENTS



4

TKS / AIR HANDLING UNIT



8

TNAS / POOL DEHUMIDIFICATION UNIT

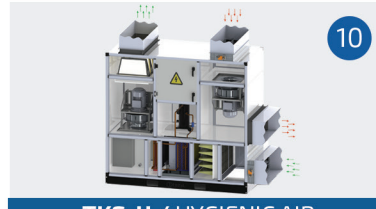

10

TKS-H / HYGIENIC AIR HANDLING UNITS



12

TKS-R / ROOFTOP



16

TIGK-HP / HEAT PUMP HEAT RECOVERY UNITS



18

TIGK / HEAT RECOVERY UNIT

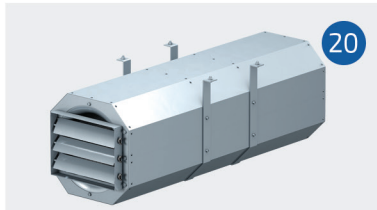

20

TDEF / AXIAL JET FAN



24

TDEF / SMOKE EXHAUST FAN



26

TKAF / AXIAL FAN



26

THMF-E / ELECTROSTATIC FILTER KITCHEN FAN UNIT



32

THMF / KITCHEN FAN UNIT

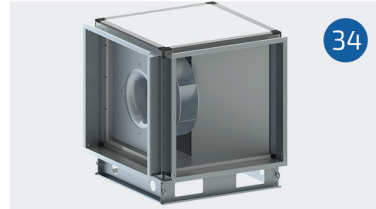

34

TMF / KITCHEN EXHUST FAN

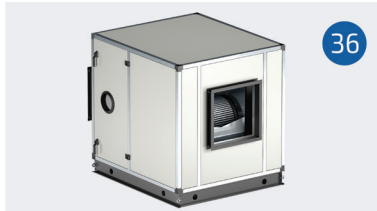

36

THF / VENTILATION UNIT



38

TEH / VENTILATION UNIT

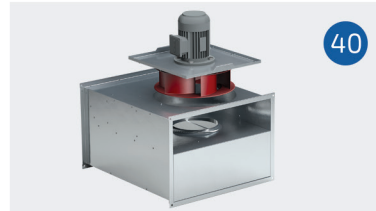

40

TKMF / DUCT TYPE KITCHEN FAN

export@tezelish.com.tr - satis@tezelish.com.tr

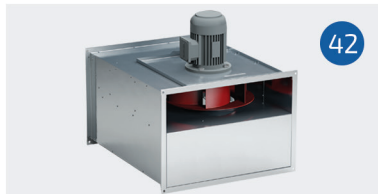

42

TKMF-EX / DUCT TYPE EXPROOF FAN

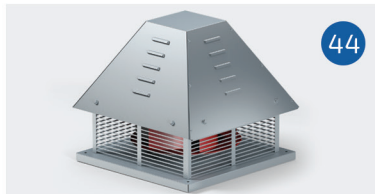

44

TBF / ROOF FAN WITH HORIZONTAL THROW MOTOR OUT OF AIR FLOW



46

TDBF / ROOF FAN WITH VERTICAL THROW



48

TDKF / RECTANGLE AIR DUCT TYPE FAN



50

TCF / ROOF FAN WITH HORIZONTAL THROW



52

TDCF / ROOF FAN WITH VERTICAL THROW



54

TAKF / ACOUSTIC FAN DUCT TYPE

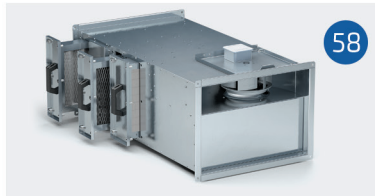

58

TKSF / DUCT TYPE FRESH AIR FAN FOR SHELTER

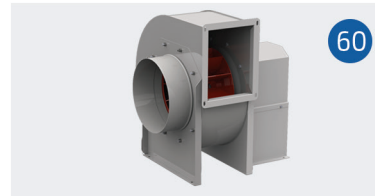

60

TSF-A / LOW PRESSURE RADIAL FANS



62

TYKF / CYLINDRICAL IN-LINE RADIAL FANS



64

TDA / AXIAL FANS



66

CERTIFICATE





ROOFTOP

TKS-R

Roof-top compact air conditioning unit is a compact and combined air conditioner which gathers the air conditioning unit and the condenser under a single structure, and where the cooling or heating cycle occurs in the same unit. These devices provide an entire air conditioning which includes cooling and heating control, ventilation and air cleaning. In addition, they are "air-to-air type" conditioners because the environment, in which the heat is provided and given, is air. They are divided into two main types as "only cooling devices" or "both heating and cooling devices". The heating function can also be provided through the use of the electrical heater, hot water battery or gas combustion module in addition to the operational function as the reverse-cycle heat pump.

The systems of roof-top compact air conditioning unit are generally suitable for places where there are not any central systems installed or planned to be installed. Almost all alternatives to air conditioning units can be provided by the relevant system. For instance, an opportunity for ambient air up to 100% in addition to the various mixture ratios on fresh air can be provided. Modular Air Conditioning Unit systems are used through the opportunities for free cooling, night cooling and heat recovery (plate or drum). Cooling can be provided through different methods such as heating and DX (direct expansion) with water, DX (direct expansion) heat pumped and direct-fired heating methods in accordance with the architectural needs.

Structure

Its appearance has been designed in accordance with the external environment. Air conditioners installed outdoor ensure that air loss is minimized. In addition, the inner surface and the exterior surface of the air conditioner can be easily cleaned. You can clean your air conditioner without any difficulty after you have taken the necessary precautions.



Compressor

A compressor performs two functions. It compresses the gas and moves it in the cycle. Thus, the compressor allows the refrigerant to perform its function continuously. The compression process necessarily loads heat to the gas. This load is called as "the Heat of Compression". The hot and compressed gas proceeds to the discharge line which is the last main part for transition to the condenser.

Evaporator and Fan

The expansion valve sprays low-pressure refrigerant particles into the evaporator made of forced air type-copper tubes which conduct the heat well. Aluminum surfaces have been used on the copper pipes in order to increase the heat transfer more. This increased surface is open to the air, and such an evaporator has a fan, which absorbs the air to pass through the blades, and a fan motor. The temperature of the air passed through the blades decreases and causes a cooling effect.

Evaporators conduct the air passed through to the interior climate with the help of a fan. The heat flow occurs in the form of heat load source/circulating air / aluminum blades/copper evaporator tubes/liquid refrigerant particles. The refrigerant particles can absorb a large amount of heat because they are at the stage of transition to gaseous phase. Thus, the refrigerant, which has been reduced in pressure through the expansion valve and then expanded in surface area through the evaporator, takes the indoor heat load, gasifies with the increment of heat, and thus, the cooling procedure is completed.

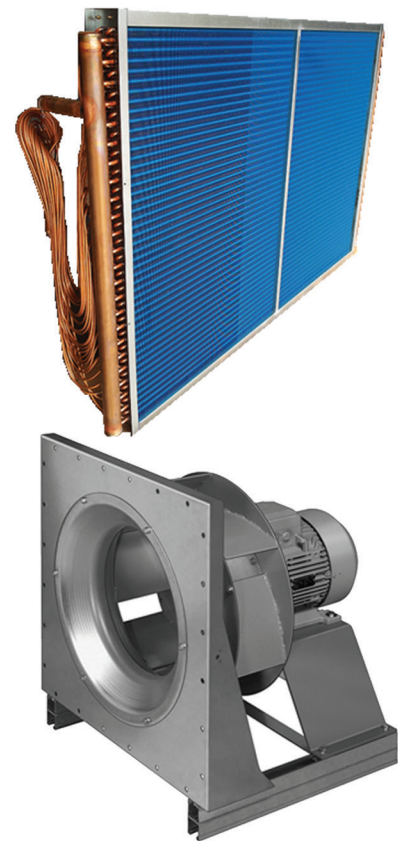

Natural Gas Burner

In cold climates, the air blown into the interior can be heated more. Thanks to the proportional natural gas burner, it operates according to the signal coming from the automation system, thus preventing over-consumption. Enough heating is provided saving energy and without polluting the nature.

Model Info

	DISCREPTION	CODE	UNIT	MODEL					
				TKS1015	TKS1020	TKS1515	TKS1520	TKS1525	TKS2020
AIRFLOW	NOMINAL	-		4000	5000	6000	7500	9000	11000
	MINIMUM	-	m ³ /h	3500	4000	5000	6000	7500	9000
	MAXIMUM	-		4500	5500	7000	8500	10000	12500
COOLING	COOLING CAPACITY		kW	27,1	33,4	38,3	44,6	56,7	74,3
	EER	OC	-	3,01	3,07	2,92	2,91	2,94	3,09
	EUROVENT ENERGY CLASS		-	B	B	C	C	C	B
HEAT PUMP	HEATING CAPACITY		kW	29,8	36,8	42,1	49,0	62,3	81,7
	COP	HP	-	3,31	3,37	3,21	3,20	3,23	3,40
	EUROVENT ENERGY CLASS		-	C	C	C	C	C	B
COMPRESSOR	NUMBER OF CIRCUIT	-	Unit	1	1	2	2	2	2
	COMPRESSOR TYPE	-	-	Scroll	Scroll	Scroll	Scroll	Scroll	Scroll
	NUMBER OF COMPRESSOR	-	Unit	1	1	2	2	2	2
	COMPRESSOR POWER	-	K	9,0	10,9	13,1	15,3	19,3	24,0
EXTRA HEATING	NATURAL GAS TOTAL HEATING	NG	kW	OPTIONAL					
	ELECTRICITY HEATING CAPACITY	EH	kW	OPTIONAL					
	HOT WATER COIL CAPACITY	WH	kW	OPTIONAL					
	OUTSIDE AREA SOUND POWER	-	dB(A)	75,0	75,0	78,0	78,0	80,0	80,0
DIMENSION	LENGHT	L	mm	ABLE TO DESIGN BASED ON PROJECT					
	HEIGHT	H	mm						
	WIDHT	W	mm						

Capacities are based on the nominal Eurovent conditions:

Cooling: outdoor air temperature: 35°C db, 24°C wb, indoor air temperature: 27°C db, 19°C wb

Heating: outdoor air temperature: 7°C db, 6°C wb, indoor air temperature: 20°C db

The weight indicated in accordance with the EN14511-3:2013 standard is only for guidance purposes. Please see the rating label of the unit.

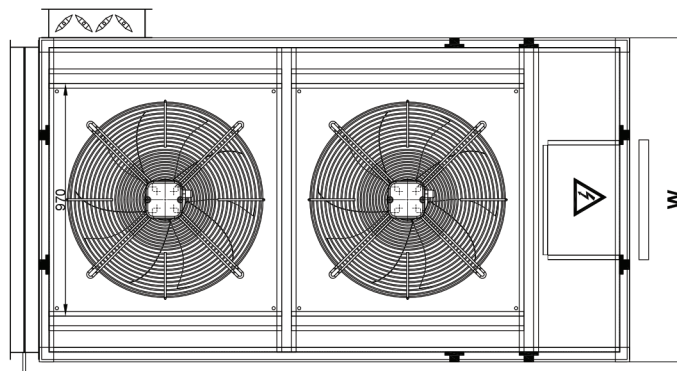

	DISCREPTION	CODE	UNIT	MODEL					
				TKS2025	TKS2525	TKS2530	TKS2535	TKS3035	TKS3040
AIRFLOW	NOMINAL	-		13500	16500	19500	23500	27500	30000
	MINIMUM	-	m ³ /h	11000	13500	16500	19500	23500	33500
	MAXIMUM	-		15500	18500	21500	25500	30000	35500
COOLING	COOLING CAPACITY		kW	88,0	107,0	120,0	158,4	185,0	205,0
	EER	OC	-	2,94	3,06	2,3	2,93	2,91	3,01
	EUROVENT ENERGY CLASS	-		C	B	C	C	C	B
HEAT PUMP	HEATING CAPACITY		kW	96,8	117,7	132,0	174,2	203,5	225,5
	COP	HP	-	3,24	3,36	3,22	3,23	3,20	3,32
	EUROVENT ENERGY CLASS	-		C	C	C	C	C	C
COMPRESSOR	NUMBER OF CIRCUIT	-	Unit	2	2	2	2	2	2
	COMPRESSOR TYPE	-	-	Scroll	Scroll	Scroll	Scroll	Scroll	Scroll
	NUMBER OF COMPRESSOR	-	Unit	2	4	4	4	4	4
	COMPRESSOR POWER	-	K	29,9	35,0	41,0	54,0	63,5	68,0
EXTRA HEATING	NATURAL GAS TOTAL HEATING	NG	kW	OPTIONAL					
	ELECTRICITY HEATING CAPACITY	EH	kW	OPTIONAL					
	HOT WATER COIL CAPACITY	WH	kW	OPTIONAL					
	OUTSIDE AREA SOUND POWER	-	dB(A)	82,0	82,0	82,0	82,0	85,0	85,0
DIMENSION	LENGHT	A	mm	ABLE TO DESIGN BASED ON PROJECT					
	HEIGHT	B	mm						
	WIDHT	C	mm						

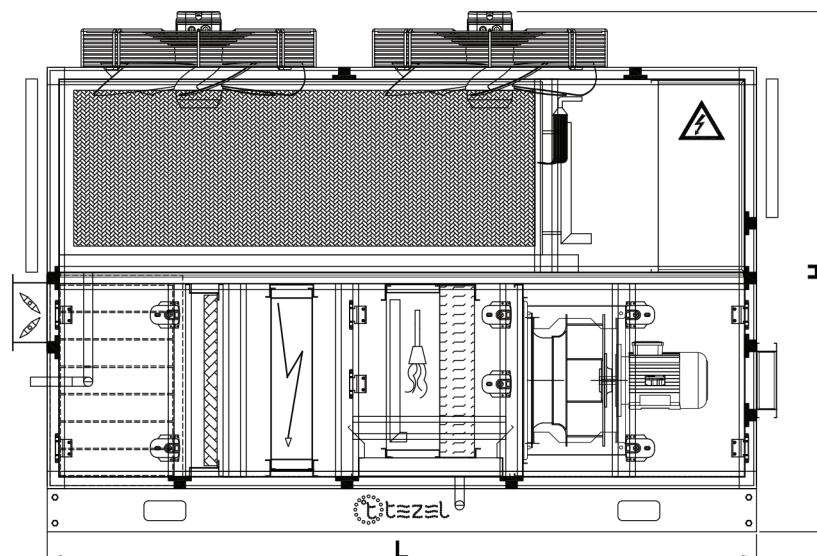



Architecture of high **quality air**



Fatih Mahallesi Yakacık Cd. Sancaktepe - İstanbul - TURKEY

www.tezelish.com.tr



+90 216 311 17 69

satis@tezelish.com.tr



+90 554 534 78 63

export@tezelish.com.tr



+90 506 365 62 54

export@tezelish.com.tr